



# Gunnebo CM SafeDeposit D3

Compact, Secure and Efficient Cash Processing

**GUNNEBO**<sup>®</sup>  
Cash Management

A **SESAMI** COMPANY



## Gunnebo CM SafeDeposit D3 family

### Higher capacity and still compact.

The D3 and D3s are part of our compact deposit unit range. They streamline daily cash processes and improve the overall efficiency of all the employees that deal with cash management.

The compact range is designed to help small to midsize retailers and carry out quick and safe cash deposit transactions with maximum adaptability to your needs. The different compact solutions adapt to your needs in terms of size, capacity and type of storage. All compact range series run with our ZEN D platform.

### Maximum security and efficiency in one compact unit

- Deposit banknotes in bag.
- Different graded safes available (to CEN type IV)
- Real time accountancy of each transaction.
- Web remote management and administration (including banknote validator upgrades).
- Multicurrency (in the same transaction!).
- Multilanguage.
- Gunnebo One Time Code system to open the safe.
- Common platform for all Gunnebo Cash Management Deposit Range.
- Visual and tactile interface via colour touch screen.
- Various cloud connections simultaneously.

#### Benefits



Multi cloud



Different identification formats



Multicurrency within one deposit



ZEN D Platform

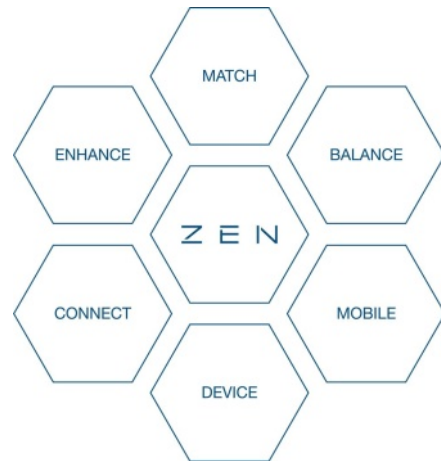

## Gunnebo Cash Management ZEN D Software

**Gunnebo Cash Management software platform for deposit devices with endless capabilities to embrace the future.**

### **Hyperconnectivity**

ZEN D connects with several cloud environments, including third-party systems, in real time with encrypted communication Protocol and open VPN by default. Connected, secure and efficient.

### **Omnipresent Access**

Manage upgrades and users for any component of the device without physically needing to be on site, reducing unnecessary visits. Increase productivity by accessing real-time data, and predictive maintenance and performance analysis, giving you flexible and intelligent control of your cash deposit devices.

### **Endless Adaptability**

Designed to be flexible and modular, ZEN adapts rapidly and efficiently with robust, long-term reliability, to your operations and individual needs.

Designed on a building block architecture with multiple configurations proven in the field.

### **Flexible Workflow**

Allows for multiple business models and licensing options. Live custom fields and configurable workflows are just some of the features of ZEN D, which adapt to your business goals.

### **Advanced Reporting**

Track everything with our live tailored reports, including advanced reconciliation reports for deposit collection and end of day and advanced cash monitoring. Designed to give you total control of your business.

Choose from the full range of ZEN Suite modules, including Balance for your finances and Enhance for your service operations.

## Specifications

### Model specifications

	D3	D3s
Capacity	Up to 2500 free fall	Up to 2300 stacked
Dimension (WxDxH)	417x690x810	417x690x810
Weight kg	254 kg	260 kg
800x480 Touch Display	7"	7"
Safe	CEN II (CEN IV, UL upon request)	CEN II (CEN IV, UL upon request)
Manual Deposit	No	No
Max. Power Specifications	250 watts. / 110-220 v.	250 watts. / 110-220 v.
Storage Type	Thermo sealed bag	Thermo sealed bag

### Standard features

Deposit Speed	20 banknotes/minute
Multicurrency deposits	Yes
Multilanguage	Yes
Multiserver connection	Yes
Real-time registration of each transaction	Yes
System	Linux Embedded OS
Software Platform	ZEN D
Receipt printer	57 mm paper width
Operating temperature	10° to 40°C
Remote management	User management, software updates...
Remote note reader update	Yes
Remote data import & export	Yes
Time settings	Supports NTP synchronisation
"Unified POS" standard	Yes
Certifications	CE, ROHS, ECB (banknote reader)
Humidity	30%-85% relative, non condensating

### Options

Bank Note Feeder	20 banknotes capacity
Barcode Reader	for users and bag / cassette identification
One Time Lock	Gunnebo electronics and algorithm
Additional locks or ID devices	Please contact Gunnebo Cash Management
Application customization	Please contact Gunnebo Cash Management

# Gunnebo CM SafeDeposit D3



## Dimensions D3

### Storage Options

2500 free fall

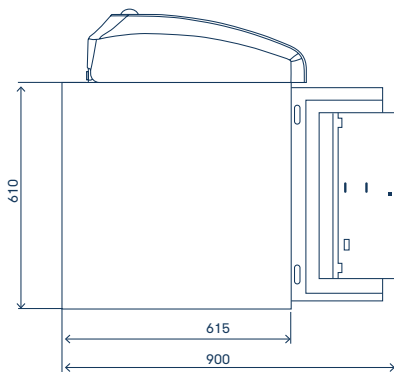

Find the right solution for you!

### Cash Monitoring Software

Complete control over your cash handling operations with business analytics, service monitoring, end-to-end cash reconciliation and multi-device connectivity.

### Cash Deposit Solutions

Save time and money with smart cash deposit solutions for retail front and back office.

### Cash Recycling Solutions

Optimise your cash flow and keep cash circulating efficiently with cash recycling solutions for retail.

### SafePay Closed Cash Management

SafePay replaces traditional tills with a smart recycling system which protects cash from payment all the way to the cash-counting centre.

### Bank Solutions

Cash automation solutions which support bank branch transformation and cut the time staff spend working with cash.

### Service

Expert support ensures that your systems run smoothly and efficiently with minimal disruption to your business.

---

**Gunnebo Cash Management creates a more efficient and secure cash cycle to help you reduce the cost of cash handling.**

---



Talk to one of our experts:  
[blog.gunneboCashmanagement.com](http://blog.gunneboCashmanagement.com) or  
[gunneboCashmanagement.com](http://gunneboCashmanagement.com)

**GUNNEBO**<sup>®</sup>  
Cash Management

A **SESAMI** COMPANY